

S SERIES STEEL SHEET PILING

ASTM A572 Grade 50 Steel

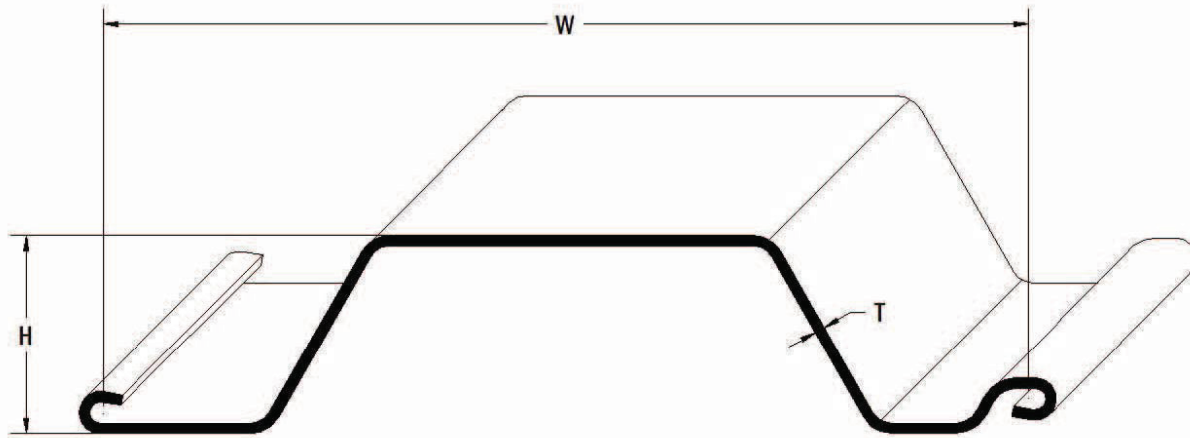

Section	Thickness in (mm)	Height in (mm)	Nominal Width in (mm)	Cross Sectional Area in ² (cm ²)	Pile Weight lbs/lin ft. (kg/lin m)	Wall Weight lbs/ft ² (kg/m ²)	Moment of Inertia in ⁴ /wall ft (cm ⁴ /wall m)	Section Modulus in ³ /wall ft (cm ³ /wall m)	Coating Area Both Sides ft ² /ft m ² /m
S64	0.250 (6.35)	5.91 (150)	27.75 (705)	9.97 (64.4)	33.90 (50.4)	14.7 (71.7)	24.00 (3280)	7.89 (424)	5.90 (1.80)
S80	0.313 (8.00)	5.97 (152)	27.75 (705)	12.36 (79.7)	42.10 (62.6)	18.20 (88.8)	30.00 (4100)	9.82 (528)	5.90 (1.80)