

NOZZLE CHART	
NOZZLE ID	NPT SIZE
N1	1/4
N2	1
N3	1 1/4
N4	3
N5	6
N6	MANWAY

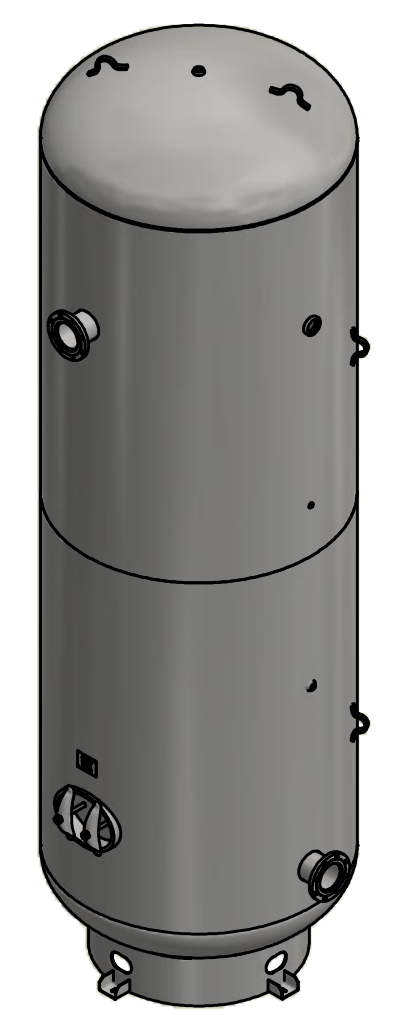
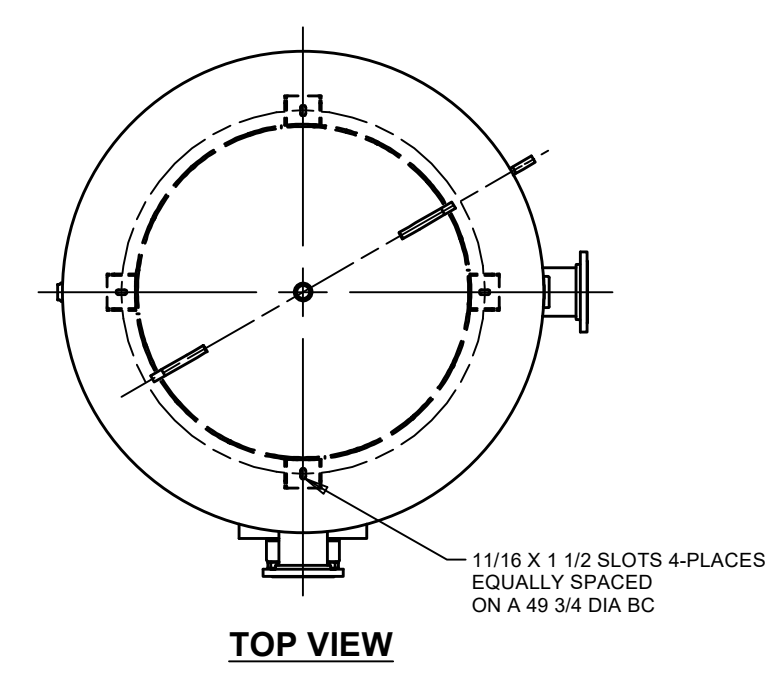
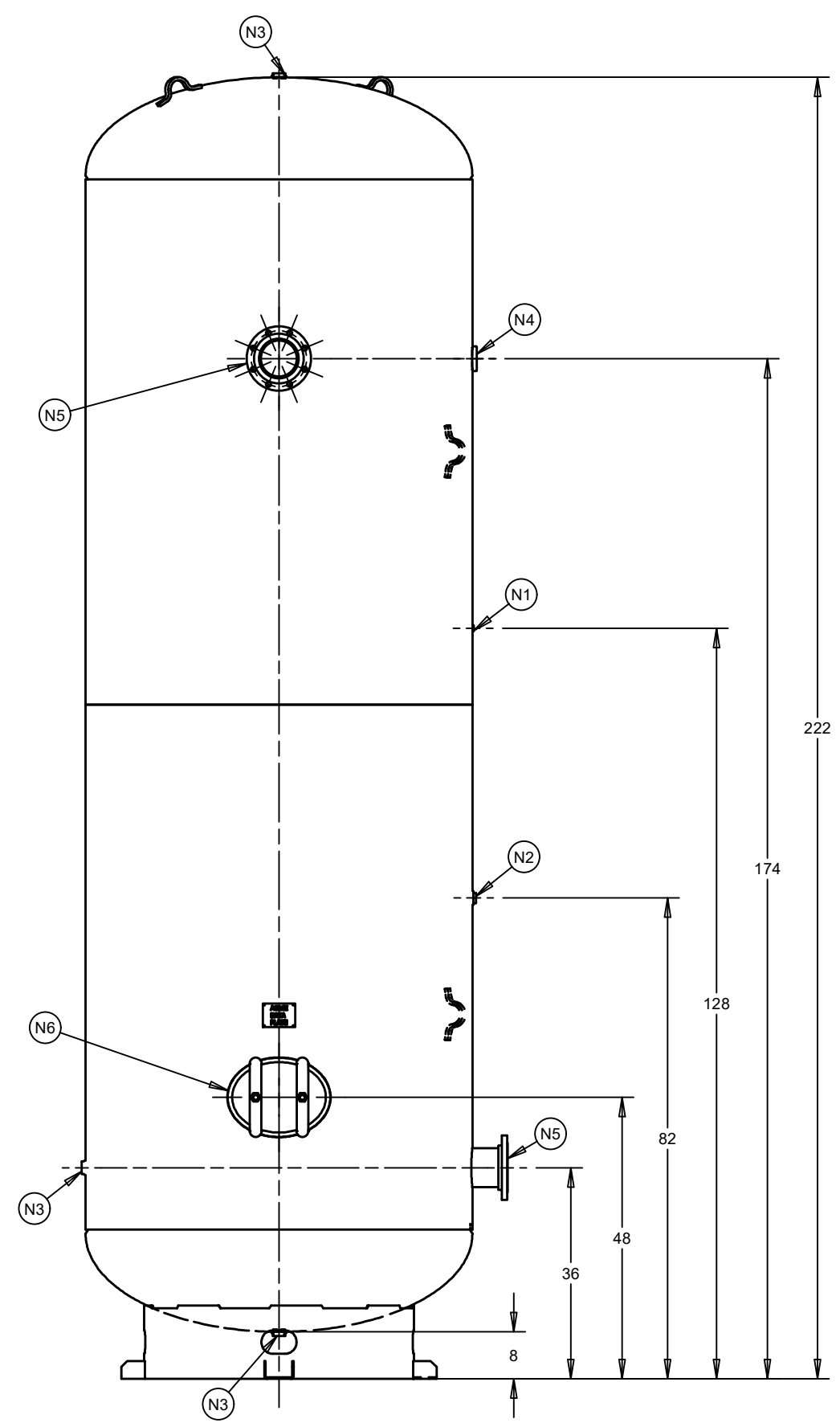

DESIGN INFORMATION	
SPECIFICATION	VALUE
DIAMETER O.D./I.D.	66 O.D.
MAWP	150 PSI AT 400°F
MDMT	-20°F AT 150 PSI
CAPACITY	APPROX 3000 GALLONS
SHIPPING WEIGHT	5385 LBS
CRN	L7682.561T5

TITLE VERTICAL AIR RECEIVER					
CUSTOMER STOCK					
TYPE ASME		DATE 10/5/2016	DATE 10/17/2016	SIZE: B SHEET 1 OF 1	

REV	DESCRIPTION	BY	DATE
F9	ISSUED		

(BUILT IN ACCORDANCE WITH LATEST EDITION OF SECTION VIII DIV 1 ASME CODE)

THIS DRAWING & SPECIFICATIONS ARE PROPERTY OF SPVG AND MAY NOT BE COPIED, REPRODUCED, OR USED IN WHOLE OR PART, AS A BASIS FOR DESIGN MANUFACTURE OR SALE WITHOUT PRIOR PERMISSION FROM SPVG.