

EQUIPMENT SOLUTIONS

For the Forestry Industry



YOUR SUCCESS IS OUR BUSINESS

SAMUEL¹⁸⁵⁵
PACKAGING SYSTEMS GROUP

SAMUEL SLP-25

Compression Strapping Machine for the Lumber and Panel Industries



Multiple magazine bunk dispensers



Automatic top and bottom edge protection using flat fibreboard protectors



Compression system

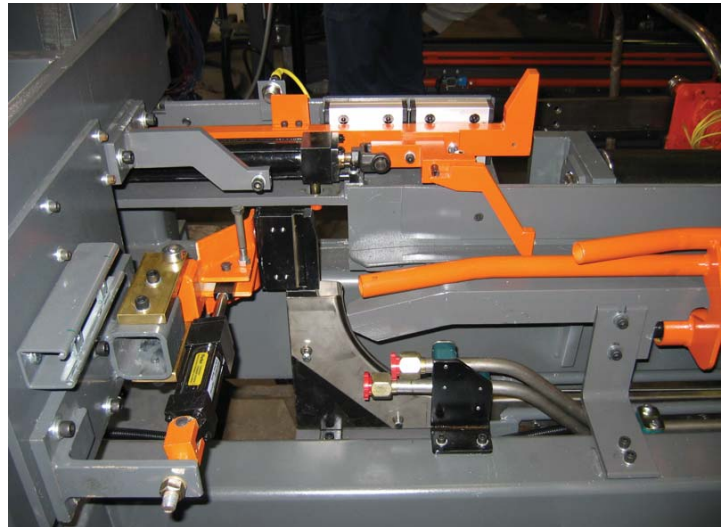

Independent bunk locator

FEATURES

- Rugged structural steel tube makes it the strongest and heaviest in its class and resists torsional stresses during compression
- Top platen safety pins support the weight of the raised top platen during service work
- Rack and pinion equalizer for positive load squaring and maintenance free operation
- Flat fibre edge protectors are available on all corners for complete package protection
- Up to 25,000 lbs. top compression and up to 21,000 lbs. side compression
- Allen Bradley Compact Logix based control system with diagnostics
- Automatic multiple magazine bunk dispenser for total automation
- Available VK30 polyester strapping head with floating head mount
- Available VS 11-LE sealless steel strapping head
- Service lockout at control panel
- Hydraulic power provided by high-efficiency, whisper quiet variable displacement pump system
- Modular design concept allows greater flexibility for custom applications

800-323-4424
packaging@samuel.com

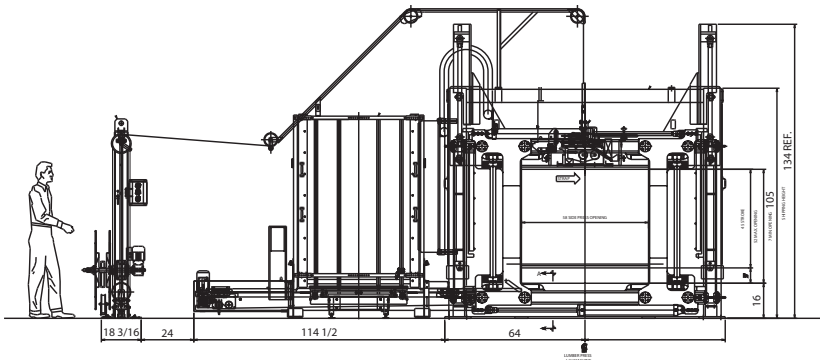
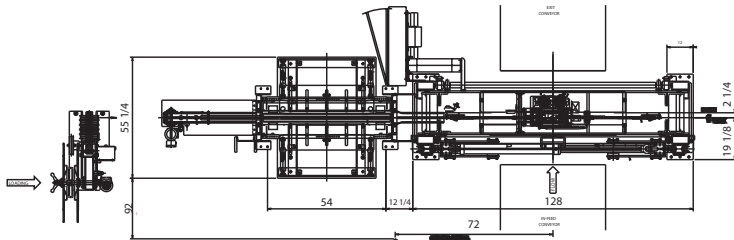

EQUIPMENT SOLUTIONS

For the Forestry Industry

SPECIFICATIONS

OPERATION

- Automatically indexes, squares, compresses and straps or can be operated manually by pressing a single cycle button

MACHINE OPENING

(Optional sizes available)

- Height: Max. (52 in.) (1321 mm)
Min. (4 in.) (102 mm)
- Width: Max. (58 in.) (1473 mm)
Min. (22 in.) (560 mm)

STRAPPING SIZE

- Steel strapping: 5/8" and 3/4" from .015" up to .023" thick
- Plastic strapping: 5/8" and 3/4" from .020" up to .050" thick

STRAP JOINT

- Up to 90% of strap strength (PET only)

COMPRESSION

- Up to 25,000 lbs. top compression
and up to 21,000 lbs. side compression

STANDARD EQUIPMENT

- Available VK30 polyester strapping head with floating head mount
- Available VS 11-LE sealless steel strapping head
- Easy tilt head mount for ease of service
- Standard dispenser to suit your requirements
- Control console fully prewired
- High-low platen stop
- Rack and pinion equalization for top and side compression
- 5 in. diameter solid steel reaction roller
- Total electro-hydraulic operation
- Custom configurations to suit your exact layout requirements
- Safety lock out system
- Platen mounted emergency tape switch
- Independent bunk locator device standard on machines without side compression

OPTIONAL EQUIPMENT

- Top and bottom edge protector units
- Single or multiple magazine bunk feed units available
- Side compression system
- VK30M polyester strapping head and powered head float system for high tension applications
- Multiple dispenser options for standard and jumbo coil configurations
- Freestanding automatic top bunk applicator
- Common sided option
- Short package option



MODEL VK30 POLYESTER STRAPPING HEAD

- Heavy duty strapping head for lumber applications
- Direct drive system delivers high tension with no belts or clutches
- Fastest heavy duty strapping head on the market
- Precision thermocouple heater blade control allows consistent seals regardless of ambient temperature



VS 11-LE SEALLESS STEEL STRAPPING HEAD

- Rugged and reliable, electronically actuated head, with floating head mount
- Sealless system for cost savings
- Servo technology for high speed and reliability with steel strapping

© September 2017 - 122744

800.323.4424
packaging@samuel.com

SAMUEL 1855
PACKAGING SYSTEMS GROUP