

MODELS S0425/S0425A

Strapping Machines

The Benchmark in
Industrial Strapping Machines.

FEATURES

- 50 cycles per minute
- Strap widths of 5mm to 12mm
- Direct drive DC brushless
- Tool-less access
- Premium controls
- Best in class performance and reliability



YOUR SUCCESS IS OUR BUSINESS

SAMUEL 1855
PACKAGING SYSTEMS GROUP

MODEL S0425

Strapping Machines

SPECIFICATIONS

Capacity		Up to 50 straps/min	
Bundle Size	Max. Width	610 - 813 mm	24" - 32"
	Min. Width	76 mm	3"
	Max. Height	330 - 813 mm	13" - 32"
	Min. Height	6 mm	1/4"
Strapping Material	Type	Polypropylene (PP- strap)	
	Width	5 - 12 mm	1/4" - 1/2"
	Thickness	min. .330 - .711 mm	min. .013" - .028"
Seal Method		Thermal Welding Seal	
Dimensions of the Strapping Coil	Core Diameter	203 - 229 mm	8" - 9"
	Outside Diameter	445 mm	17 1/2"
	Width	165 - 210 mm	6 1/2" - 8 1/4"
Electrical Supply		115 V, 1 Phase, 60 Hz	
Consumption		1.1 kW at 115 V	
Tension		max. 200 N	
Weight		300 - 600 lbs.	

FRAME SIZES

A	B	C	D	Panel
23"	13"	39"	20"	Top
23"	20"	39"	23"	Right
23"	20"	39"	26"	Top
23"	23"	39"	30"	Top
31"	23"	47"	29"	Right
31"	31"	47"	33"	Right

BASIC EQUIPMENT

- Automatic strap feeding
- Infinite adjustment of the strap tension
- maintenance-free direct drives
- Machine with wheels and castors
- Motors without mechanical clutch or brake
- PLC control (Mitsubishi) with malfunction detection system
- Short pre-heating time
- Heater exhaust fan
- Touchscreen, lockable with free programmable code

SPECIAL EQUIPMENT (extra charge)

- Air gun with spiral hose
- Automatic tension
- Light inside the machine

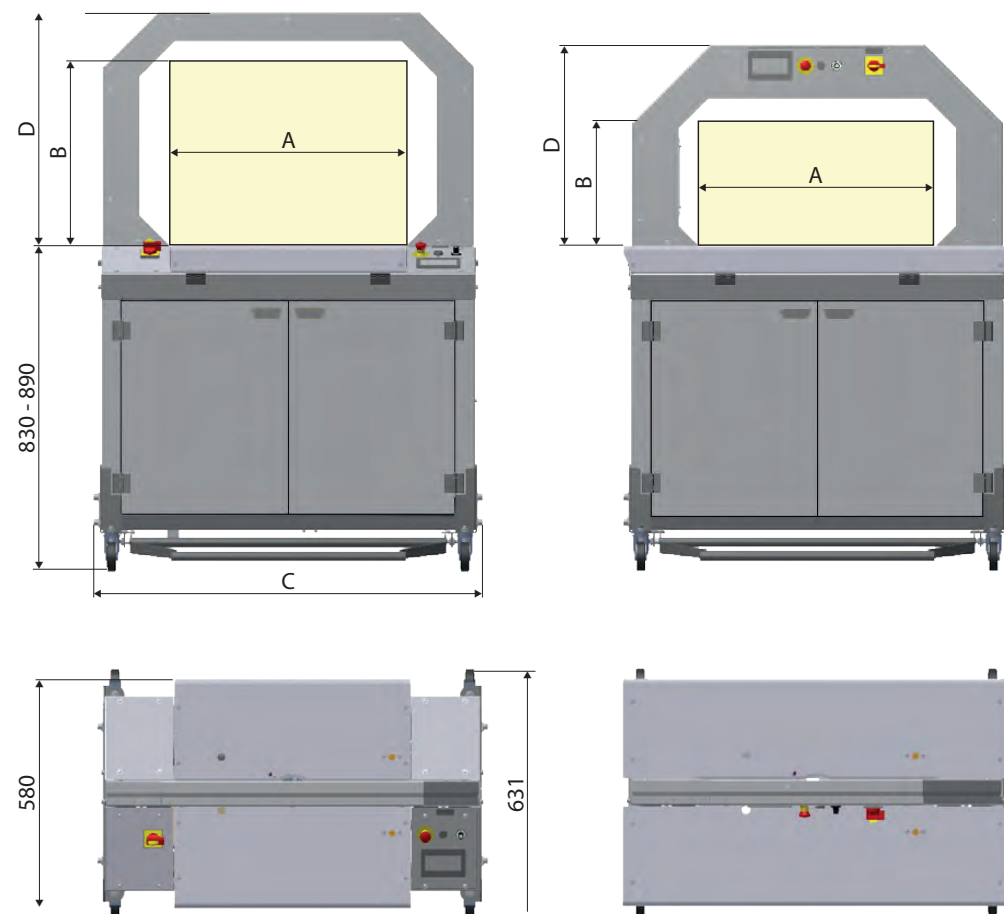

MODEL S0425A

Strapping Machines

SPECIFICATIONS

Capacity		Up to 30 single straps/min Up to 15 parallel straps/min	
Bundle Size	Max. Width	610 - 813 mm	24" - 32"
	Min. Width	152 mm	6"
	Max. Height	483 - 788 mm 381 - 686 mm	19" - 31" (without bundle press) 15" - 27" (with bundle press)
	Min. Height	12 mm	1/2" (with auto tension)
Bundle Weight	Max.	25 kg	55 lbs.
Strapping Material	Type	Polypropylene (PP- strap)	
	Width	5 - 12 mm	1/4" - 1/2"
	Thickness	min. .330 - .711 mm	min. .013" - .028"
Seal Method		Thermal Welding Seal	
Dimensions of the Strapping Coil	Core Diameter	203 - 229 mm	8" - 9"
	Outside Diameter	445 mm	17 1/2"
	Width	165 - 210 mm	6 1/2" - 8 1/4"
Electrical Supply		115 V, 1 Phase, 60 Hz	
Electrical Requirement		1.1 kW	
Pnumatic		Working Pressure: 4 bar	
Consumption		Single Machine: 90 l/min. (3 l/strap) free air	
Pressure of the Parcel Press		200 N (cylinder diameter 25 mm)	
Tension		max. 200 N	
Conveyor Speed		ca. 80 - 180 f/min.	
Weight		300 - 600 lbs.	

FRAME SIZES

A	B (without press)	B (with press)	C	D	E
23"	20"	16"	48"	23"	29"
23"	23"	20"	48"	23"	29"
23"	31"	25"	48"	23"	29"
31"	23"	20"	56"	31"	33"
31"	25"	23"	56"	31"	33"
31"	31"	25"	56"	31"	33"

DIMENSIONS WITHOUT BUNDLE STOPS

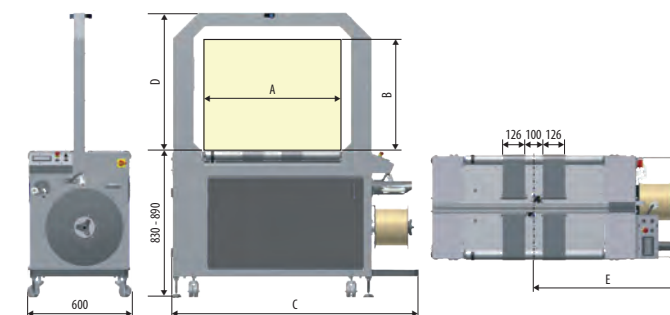

DIMENSIONS S0425A 600x500 WITH BUNDLE PRESS AND STOPPERS

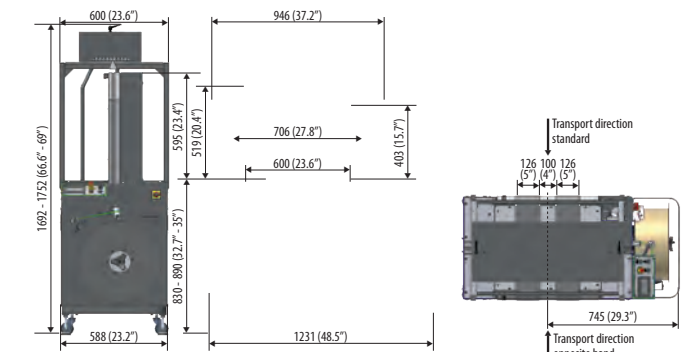

BASIC EQUIPMENT

- Automatic strap feeding and eject
- Connections for tail back in and tail back out with a plug
- Conveyor belts speed infinitely variable
- Infinite adjustment of the strap tension
- Maintenance-free direct drives
- Motors without mechanical clutch or brake
- PLC control with four adjustable programs for different products
- Short pre-heating time
- Strap control
- Strap counter
- Heater exhaust fan
- Touchscreen, lockable with free programmable code

SPECIAL EQUIPMENT (extra charge)

- Additional start-/stop- and emergency stop button at the switchboard cabinet
- Air gun with spiral hose
- Automatic tension
- Back-up function
- Bundle press with single press bar
- Conveyor belts speed infinitely variable by the touch screen
- Height scanning for the bundles
- LED signal tower with 3 lamps, inclusive spool detection
- Light at the inside of the machine
- Power supply without neutral wire
- Spool detection
- Stop bars

MODELS S0425/S0425A

Strapping Machines



S0425AC

- Fully automatic with top compression
- For telescoping boxes or other product requiring compression



S0425 SOLID TABLE TOP OPTION

- Solid tops assist debris from entering machine.
- For heavier rigid and high tension products



S0425ABC

- Fully automatic with compression and adjustable product stops
- For squaring and defined strap placement
- Primarily designed for commercial printing and newspapers



S0425ACS

- Fully automatic in stainless steel, with compression.
- For wet/damp environments
- For food/protein processing facilities

SO425 © August 2019 - 131049