

MODEL SCB100

Corrugated Bundler - Top Compression and 4-Sided Squaring



High speed corrugated strapper with integrated squaring system



STANDARD FEATURES

- Easy to use PLC touchscreen set-up
- Strap capacity up to 20 single straps and 10 parallel straps per minute
- Strap width from 5 to 12 mm
- Roller transport system
- Side compression
- Stopper
- Bundle press
- DC servo controlled motors
- Very low maintenance

TECHNICAL DATA

Capacity:

Up to 20 single straps/min
(at 40m/min, format 400mm x 260mm)

Up to 10 parallel straps/min
(at 40m/min, format 1050mm x 760mm)

Bundle size:

Width: max. 65" / 1655 mm
min. 7.8" / 200 mm

Height: max. (without bundle press) 23.5" / 600 mm
max. (with bundle press) 19.6" / 500 mm
min. (with auto. tension) 1.1" / 30 mm

Bundle weight:

max. 25 kg

Strapping material:

Polypropylene (PP- strap)

Width: 5-12 mm thickness: min. 0,40 - 0,70 mm

Seal method:

Thermal welding seal

Dimensions of the strapping coil:

Core diameter: 7.8" - 8.9" / 200/228 mm

Outside diameter: 17.7" / 450 mm

Width: 6.5" - 8.25" / 165-210 mm

Electrical supply:

115 V – 480 V, 3 Phase, 50 / 60 Hz

Electricity requirement:

1,1 kW at 400V

Pressure of the parcel press

200 N (cylinder diameter 25 mm)

Tension:

max. 200 N

Conveyor speed:

ca. 25 - 57 m/Min.

Weight:

1829 lbs. (830 kg)

(with bundle press, stopper and side compression)

BASIC EQUIPMENT

- Additional Start/Stop and Emergency Stop button at the switchboard cabinet
- Automatic strap feeding
- Colour RAL 5007 (brilliant blue)
- Connections for tail back in and tail back out with a plug
- Data exchange and failure register via USB
- Infinitely adjustment of the strap tension
- LED signal tower with 3 lamps, inclusive spool detection
- Machine with wheels and castors
- Maintenance free direct drives
- Motors without mechanical clutch or brake
- PLC control with four adjustable programs for different products
- Short pre-heating time
- Strap control
- Strap counter
- Touch screen, lockable with free programmable code
- Transport speed infinitely variable by the touch screen

SPECIAL EQUIPMENT (extra charge)

- Additional height adjustment (table height 26" - 31" / 665 -785 mm)
- Additional height adjustment (table height 37" - 53" / 945 -1350 mm)
- Air gun with spiral hose
- Automatic tension
- Cable numbering
- Light at the inside of the machine
- Power supply without neutral wire
- Special color
- Side compression entrance

SPECIAL EQUIPMENT (without extra charge)

- Operation side right

DIMENSIONS

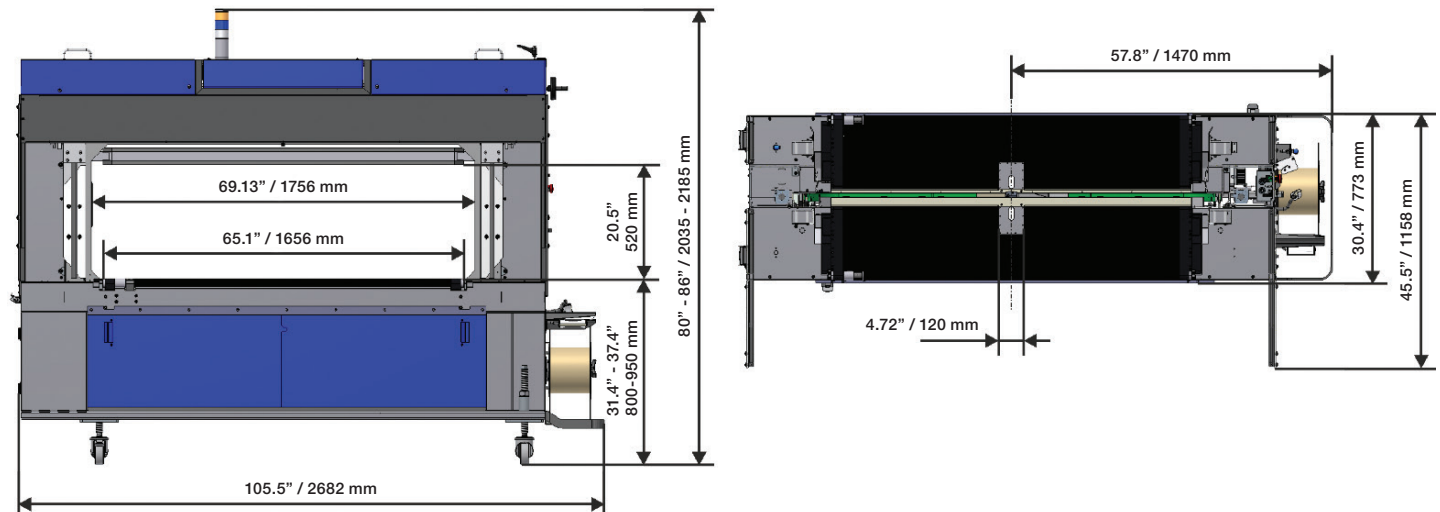

© SCB100-136380-10/21

Specifications are for guidance purposes only and subject to change without notice.

packaging@samuel.com
www.samuelpsg.com

YOUR SUCCESS IS OUR BUSINESS

U.S.A: 800-323-4424
Canada: 800-607-8727

SAMUEL
PACKAGING SYSTEMS GROUP