

MODEL P702CQ3

High Speed corrugated Strapper with Integrated Squaring System



FEATURES

- Bundler and Integrated 3-Side Squaring
- 24 Bundles per Minute, single Strap
- Proven 702C Strapping Head Technology
- FAST Setup and Size changes
- Siemens PLC and HMI
- Small Footprint, Similar to Standard 702C
- Adjustable Conveyor Speed
- Adjustable Conveyor Height
- Unique All Electric, DC Direct Drives
- Including Top Press, Side Press and Backstop

MODEL P702CQ3

High Speed corrugated Strapper with Integrated Squaring System

PRODUCT DESCRIPTION

The P702CQ3 is an **all-electric** high-speed corrugated strapper with integrated squaring and backstop functions. It is built on the quality proven P702C corrugated strapper and carries all the innovative features of the P702C. Motorized squaring and backstop devices provide precise bundle handling and positioning for forming perfect bundles.

The P702CQ3 uses the latest DC brushless motor direct drive technology to provide the highest level of accuracy and reliability in the market. With a compact design and fewer moving parts, the P702CQ3 requires fewer adjustments, has fewer wear components, reduces repair time and minimizes maintenance costs.

OTHER OPTIONS:

- Conveyor height elevation kits up to 60"
- Voltage options
- Dual dispensers with auto load in 20 seconds
- Energy saving Sleep mode
- Tandem machine with dual strapping heads

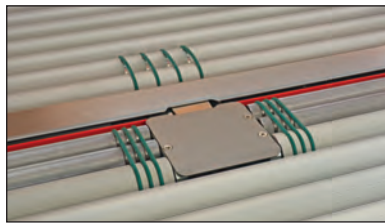
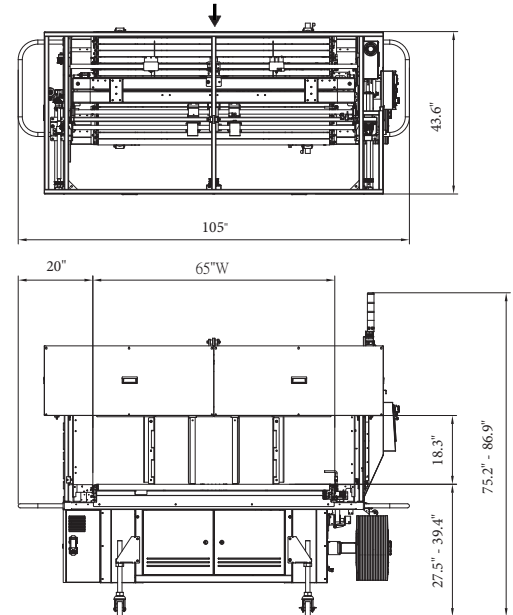

For small bundles



Squaring front

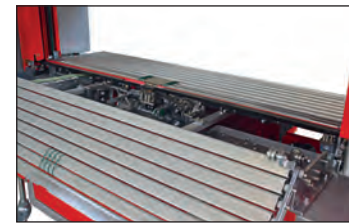

Table open

SPECIFICATIONS

Width	2668 mm	105"
Height	1908 - 2208 mm	75" - 87"
Depth	1108 mm	43.6"
Machine Weight	826 kg	1817 lbs
Shipping Weight	916 kg	2015 lbs
Arch Size	W 1650 x H 450 mm	W 65" x H 17 ³ / ₄ "
Conveyor Elevation	700 - 1000 mm	27 ¹ / ₂ " - 39 ³ / ₈ "
Conveyor Speed	15 - 60 M/minute	49 - 197 Ft/minute
Strap Width	5, 6, 9 mm	1/4", 3/8"
Strap Tension	1 - 32 kg	2 lb - 70 lbs
Strapping Speed	Up to 24 bundles/minute (single strapped) – 13 bundles/minute (double strap)	
Minimum Pkg. Size	L 250 x W 200 x H 50 mm	L 9 ⁷ / ₈ " x W 7 ⁷ / ₈ " x H 2"
Maximum Pkg. Size	W 1420 x H 450 mm	W 56" x H 17 ³ / ₄ "
Maximum Pkg. Weight	35 kg	77 lbs
Press Bar Pressure	50 kg	110 lbs
Power Supply	240/480 3 Phase	

© P702CQ3-126147-09/18.
Specifications are for guidance purposes only and subject to change without notice.

1-800-323-4424
packaging@samuel.com

SAMUEL
PACKAGING SYSTEMS GROUP